

solids Multi-Way Diverter

Type MWW



Distributor for pneumatic pressure conveying pipelines or collection of vacuum conveying pipelines, up to 20 exits; can also be used as a collector; smooth and shock-free material flow; no dead zones



Advantages:

- **Suitable for all bulk solids**
- **Approved as per pressure equipment directive 97/23/EC**
- **No dead zones, no product residues**
- **Robust and fail-safe**
- **Versions: Temperature-resistant up to 250° C**
 - Wearing-resistant with ceramic coating**
 - Anti-adhesion with plastic or rubber coating**
 - “Clean” in stainless steel**
 - Crack-free, easy to dismantle, conform to FDA rules**

S.S.T.-Schüttguttechnik Maschinenbau GmbH
Lechwiesenstr. 21, 86899 Landsberg / Lech
Tel. 0049 (0)8191-3359-50 / Fax 0049 (0)8191-3359-55
E-mail SST@solids-service.de www.solids.de



solids Multi-Way Diverter

Type MWW



Characteristics:

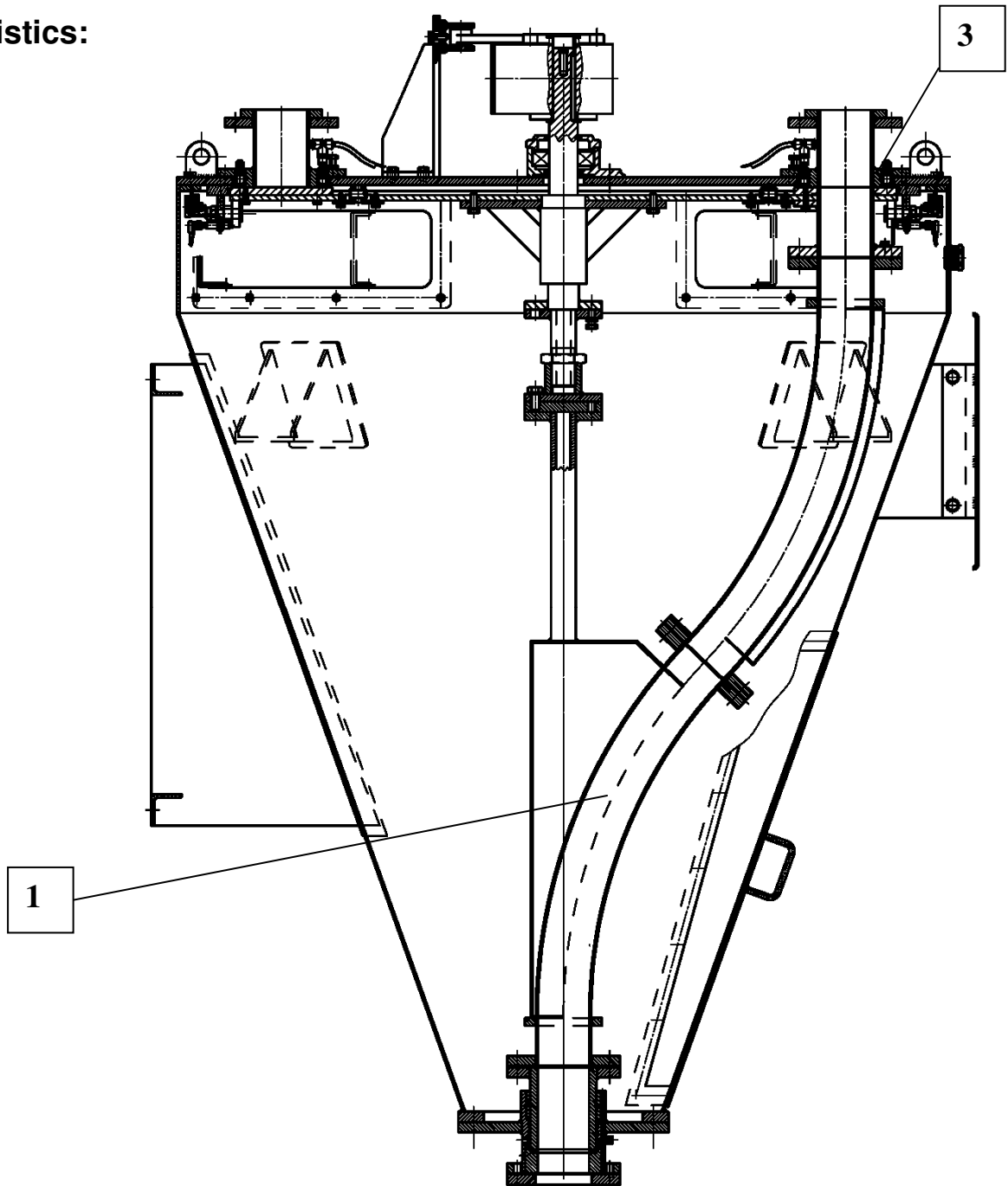

- 1) Stable, sturdy design; thick-walled steel pipe
- 2) Coatings for wearing-resistant or anti-adhesion, "Clean" for food-industry, conform to FDA rules
- 3) Pressure-tight up to 6 bar due to inflatable sealings
- 4) Can be used as a distributor or collector
- Nominal widths from Ø50 - 200 mm
- 3 to 20 exits

S.S.T.-Schüttguttechnik Maschinenbau GmbH
Lechwiesenstr. 21, 86899 Landsberg / Lech
Tel. 0049 (0)8191-3359-50 / Fax 0049 (0)8191-3359-55
E-mail SST@solids-service.de www.solids.de



solids Multi-Way Diverter

Type MWW



Function:

The multi-way diverter is installed in a pneumatic conveying system and is used to switch over the conveying flow to different exits.

The exit for the desired target location is selected before starting the pneumatic conveying; the distributor pipe then moves to this exit. All exits are pneumatically sealed after reaching the position.

The incoming conveying pipeline is connected with the outgoing pipeline through the distributor pipe which is rotated by a worm geared motor. The distributor pipe is supported in a bearing bush in the inlet collar and in a ball joint bearing with casing. Contactless limit switches are provided for positioning and the position feedback. Limit switches are set in the factory such that the brake of the worm geared motor stops the distributor pipe when it aligns with the exit. When this status is reached, the solenoid valve opens and all pneumatic sealings are pressed simultaneously. The pressure of compressed air at the pressure reducer must be set 2 bar above the conveying pressure. A pressure switch monitors the contact pressure. The equipment can be installed in any position.

Detail exit with an inflatable sealing:

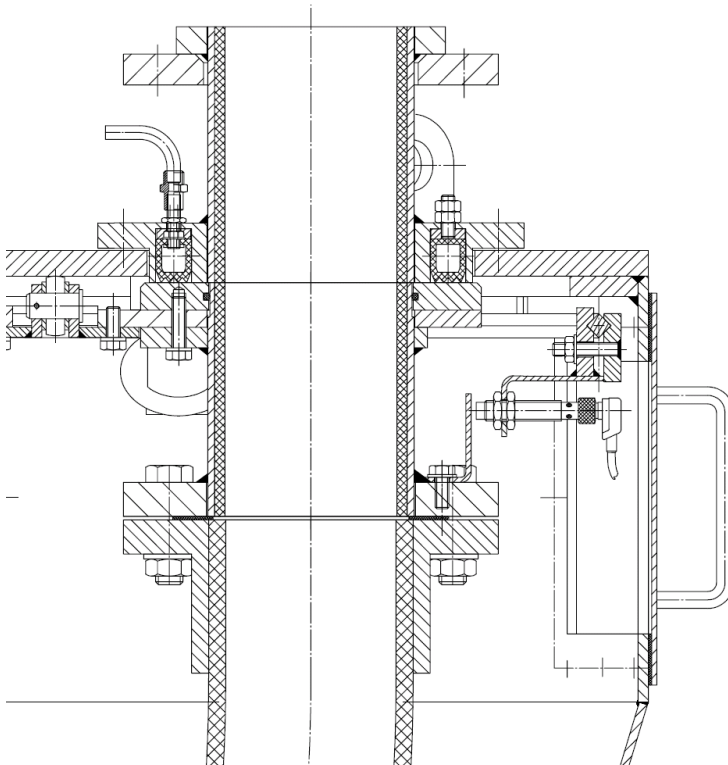

S.S.T.-Schüttguttechnik Maschinenbau GmbH
Lechwiesenstr. 21, 86899 Landsberg / Lech
Tel. 0049 (0)8191-3359-50 / Fax 0049 (0)8191-3359-55
E-mail SST@solids-service.de www.solids.de



solids Multi-Way Diverter

Type MWW



Abrasive resistant design:

Diverter pipe and connections with ceramic lining or hardened / heavy-walled pipe

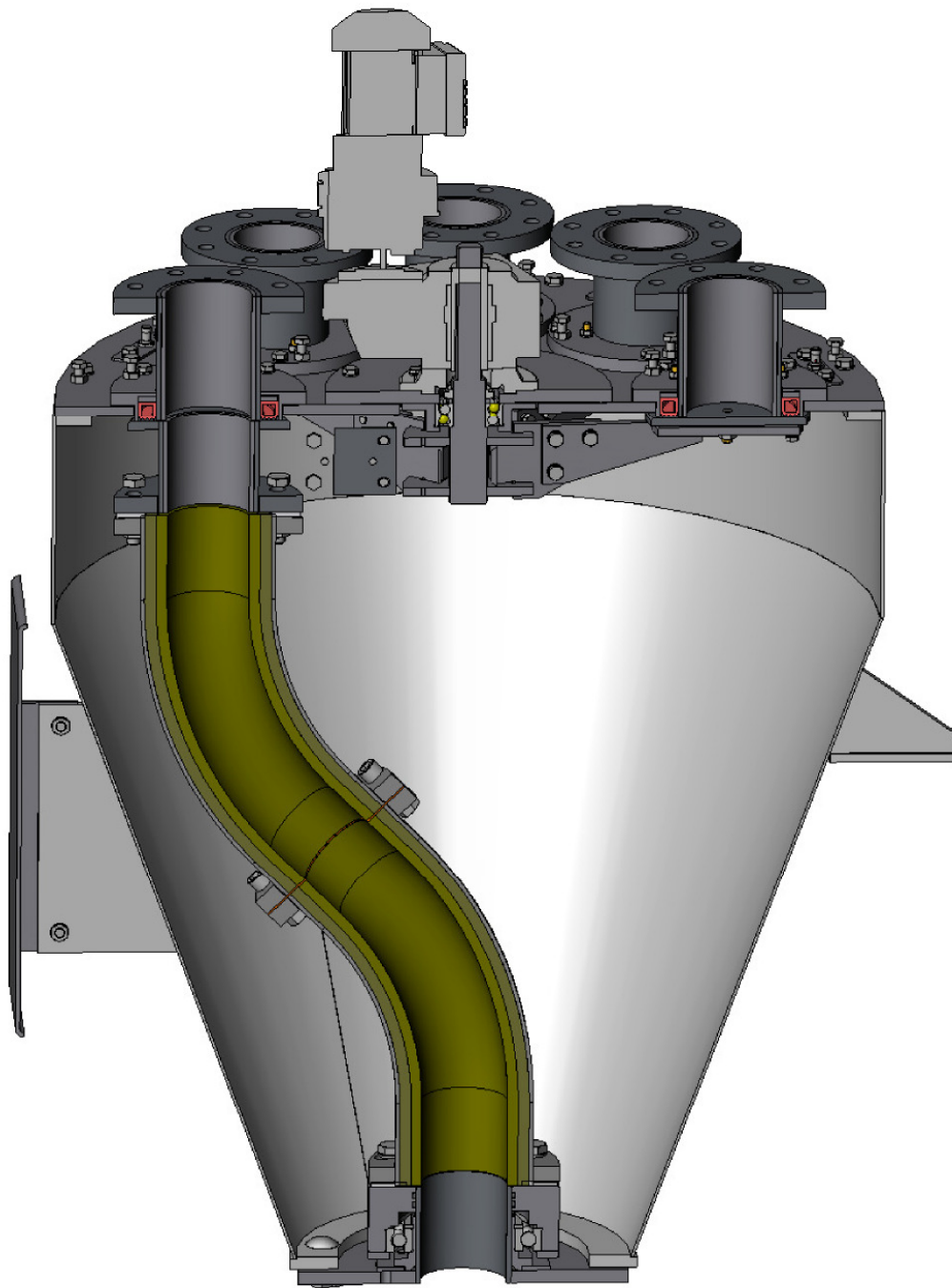

S.S.T.-Schüttguttechnik Maschinenbau GmbH
Lechwiesenstr. 21, 86899 Landsberg / Lech
Tel. 0049 (0)8191-3359-50 / Fax 0049 (0)8191-3359-55
E-mail SST@solids-service.de www.solids.de



solids Multi-Way Diverter

Type MWW



Anti-adhesion design:

Diverter pipe and connections with PE-pipe or elastomer, clean, impulse-free flow of material

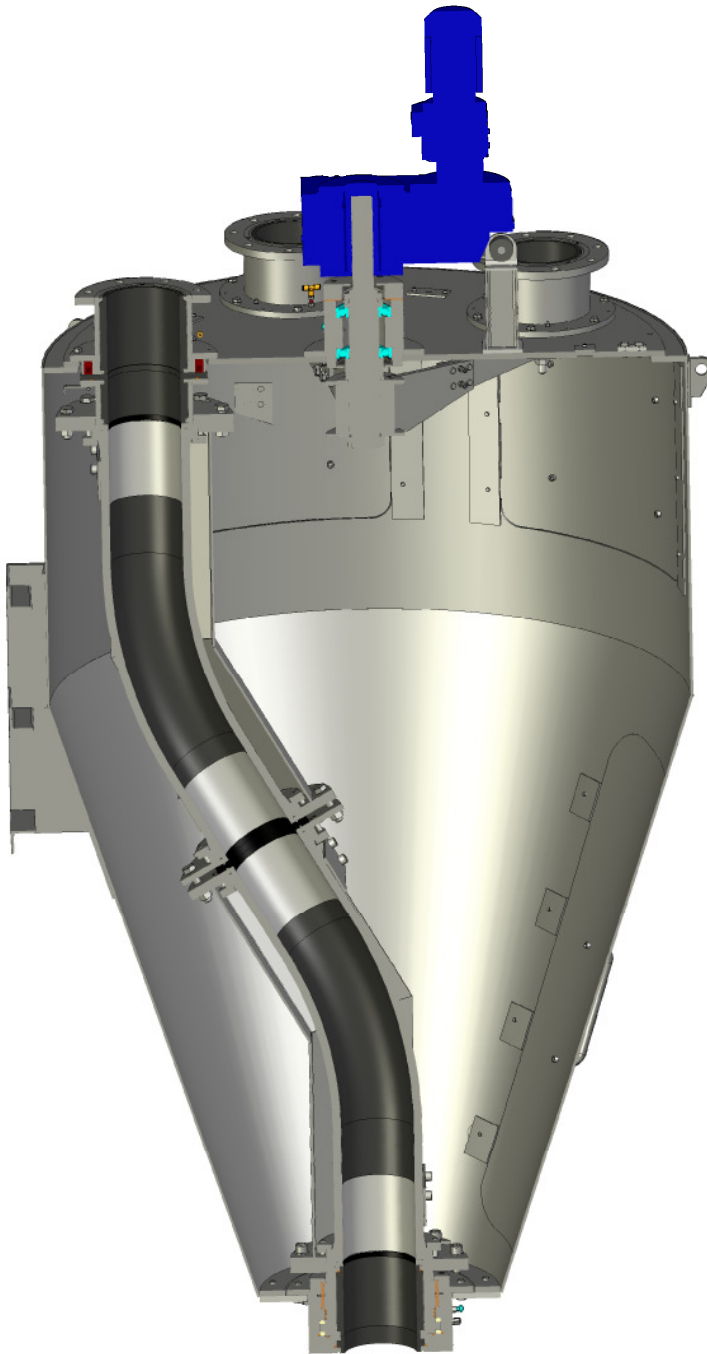

S.S.T.-Schüttguttechnik Maschinenbau GmbH
Lechwiesenstr. 21, 86899 Landsberg / Lech
Tel. 0049 (0)8191-3359-50 / Fax 0049 (0)8191-3359-55
E-mail SST@solids-service.de www.solids.de



solids Multi-Way Diverter

Type MWW



Clean-design:

Stainless steel, no gaps, no joints, easy to dismantle, CIP, piggable

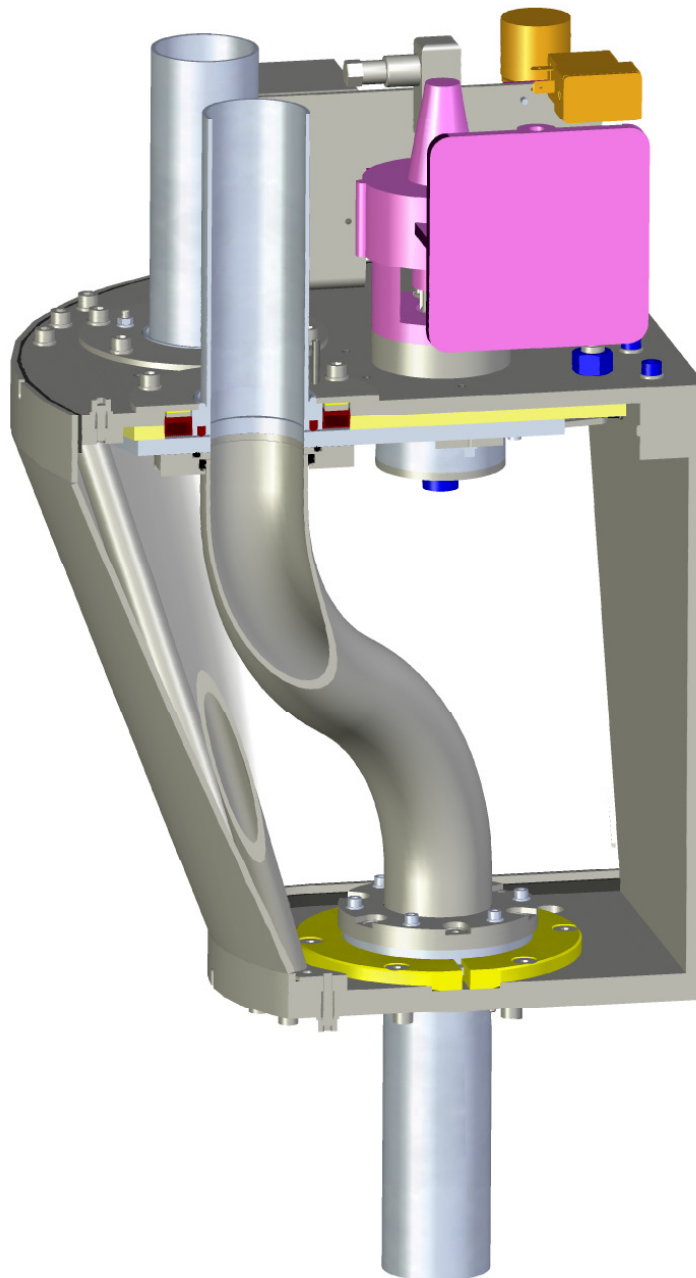

S.S.T.-Schüttguttechnik Maschinenbau GmbH
Lechwiesenstr. 21, 86899 Landsberg / Lech
Tel. 0049 (0)8191-3359-50 / Fax 0049 (0)8191-3359-55
E-mail SST@solids-service.de www.solids.de

